

Evaluating Computer Modeling, Simulation & Animation

Presentation at the 21st IATAI Conference By Brian G. McHenry *McHenry Consultants, Inc*

"Computer programs can be used...However the mere fact that the results came from a computer does not make the answers accurate. You should always make a careful review of the input variables and how sensitive the outputs are to these inputs. This applies whether you are using a computer or a hand-held calculator".

From: Traffic Accident Reconstruction, Northwestern Traffic Institute

"With the rapidly increasing capabilities and capacities of computers, there is a growing inventory of commercially available, special purpose computer programs that deal with a wide variety of technical topics. This trend is clearly present in the field of highway accident reconstruction.

Since many of the applications of accident reconstruction programs are aimed at courtroom presentations, recent emphasis in this field is being placed on the development and use of high resolution digital graphics as opposed to the development of more accurate reconstructions. Such graphics capabilities permit the creation of animations in which anything imagined can be made to look very real. An example of the recent emphasis in the field on image over substance is the relatively widespread use of spline fits to control high-resolution animation sequences which are sometimes inconsistent with Newtonian dynamics.

As scientists, engineers and accident reconstructionists, we should not let the unlimited possibilities of making anything look real (with animation) obscure our duty to perform a careful and detailed engineering analysis while also continually testing and evaluating the applied techniques, including computer programs, to achieve the most accurate reconstruction possible".

From: McHenry Accident Reconstruction 2003, McHenry & McHenry

We live in fantastic times! Computer capacities and capabilities are phenomenal! Today, on a PC or MAC laptop or desktop, anyone can easily and affordably make 3-Dimensional animations which can rival Hollywood's best. Also, computer simulation programs which were developed and could only run on million dollar machines can now be easily run on your personal computer.

With these newfound capabilities, it is very easy to make anything imagined look very realistic.

For example, a sample application which is included with many animation programs is how to make a cow fly! By following the example, anyone can create an animation of a cow flying. And very quickly and easily someone could create a very realistic animation such that upon viewing the animation you might believe that cows do indeed fly! So now let's say there is a court hearing to determine whether cow's fly. And at the court, an expert with an advanced degree from an esteemed university and years of experience testifies that 'cows can fly!' and as part of the testimony the expert offers a video to prove it! Well everyone know that cows don't fly, yet, when the expert, impressive in his academic credentials, counters that argument and supplements it with a realistic animation of a cow flying, the jury may be swayed to believe something that is obviously not true.

In consideration of the extreme example you might be able to begin to understand the problems which can occur with improper application of animation and/or simulations in litigation.

In the field of accident reconstruction there is an increasing use (and abuse) of simulation and animation techniques for demonstrative evidence purposes. So you may find yourself, either as an expert or attorney, being faced with a reconstruction which is supplemented with a computer simulation, animation or illustration. So what to do? How do we sort it out? How do you evaluate computer simulations and animations? First let us look to what is required to perform an accident reconstruction:

The process of reconstructing a motor vehicle collision involves collecting all available information about the interaction of the vehicles including vehicle trajectory information, damage information, vehicle specifications and scene information.

The trajectory information is gathered based upon the police measurements, photographs and scene evidence documentation (skid marks, gouges, etc.). To characterize the interaction of the vehicles the approximate location of the area of impact, the measured positions of rest and any skid and gouge marks should be memorialized. Technological advances in survey and measurement equipment have made equipment available to police and investigators which can quickly, efficiently and accurately memorialize vehicle accident scenes (e.g., **Figure 1**).

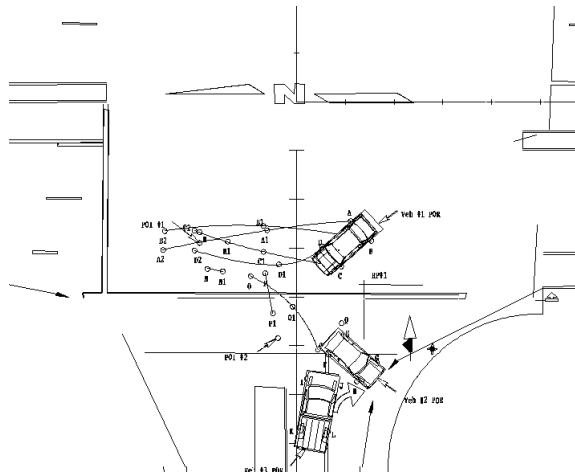

Figure 1 Sample scene diagram with measurements

The damage information includes measured dimensions of the damage locations and extents (e.g., **Figure 2**). The standard procedure by which damage is characterized is the Collision Deformation Classification (CDC, [1]) and the Equidistant Crush Measurement (ECM, [2]).

Collecting vehicle specifications and scene information (roadway layout and topography) completes the required data to permit the performance of an accident reconstruction.

Collision reconstruction techniques are then applied to make a preliminary determination of the impact speeds and impact speed changes (ΔV 's). There are two basic reconstruction techniques utilized for performing a preliminary accident reconstruction: Trajectory analysis techniques and damage analysis techniques.

Trajectory analysis techniques are based on applications of the principles of the Conservation of Linear and Angular Momentum and they frequently include the simplifying assumptions of instantaneous exchange of momentum, no consideration for tire-to-ground "external" forces during the collision, and straight line travel from separation to rest [3, p84-85].

Damage analysis techniques are generally based upon empirical relationships for the absorption and return of energy such as those defined in the work of Emori [4], Campbell [5] and the CRASH damage algorithms [6]. These damage analysis algorithms are predominantly fitted to measurements of the results of rigid, fixed barrier crash tests without direct consideration of restitution effects. As the result of a lack of

distinction in the damage analysis techniques between the effects of stiffness and restitution, the relatively simple crush model can result in substantially different vehicles sharing nearly equal slopes and intercepts in CRASH-type plots of the approach period speed-change as a function of residual crush. Such similarities in definition can occur even though the actual exposure severity for a given residual crush may be significantly different [7].

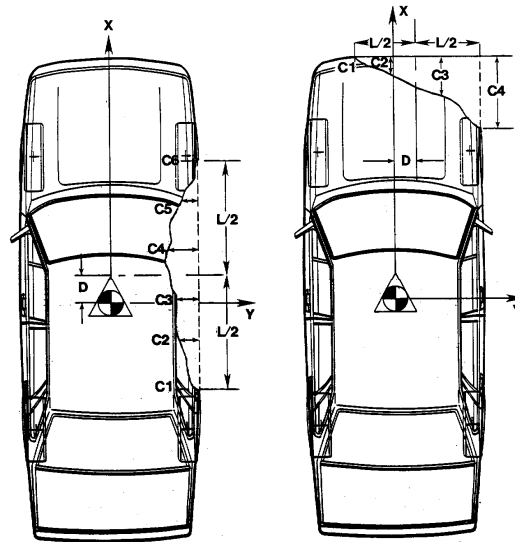

Figure 2 Sample damage dimensions

WHAT YOU NEED to evaluate any computer based reconstruction/animation.

If you are faced with someone using computer program or programs to create demonstrative evidence at trial, what do you need to evaluate what they have done? To facilitate the evaluation of an application of any of these programs, you need to obtain complete documentation of the analysis procedure.

- Request complete inputs and outputs for any and all computer programs used
 - Printed and in computer form (CD or diskette). (Printed output pages can be saved as text files and copied to a CD to save paper)
 - Most of the programs include options for outputs. The outputs should be set with ALL OPTIONS ON to obtain all the outputs and time history data, etc.
 - Request the program version, an indication of any add-ons or options used, etc.
 - If a video created, request all the files used to create the video: CAD files, Animation files, spreadsheet files, any and all notes, etc.
- Some papers and links written on the subject:
 - SAE paper number [1999-01-0101 "Computer-Generated Trial Exhibits: A Post-Daubert Update"](#)
 - SAE paper number [940920 "Case Studies in Animation Foundation"](#)
 - SAE paper number [980018, "Documenting Scientific Visualizations and Computer Animations used in Collision Reconstruction Presentations"](#) which includes as the Summary:
 - "This paper has presented a proposed standard for documenting computer generated images, animations, scientific visualizations, etc. The basic standard is that any still images or videos should be documented such that any qualified analyst can reproduce them. This is the requirement for the scientific community in general and should be adopted in the accident reconstruction community. It is important to note that this standard does not refer to any method of generating

these images or videos. There is no implication that any one method or any one graphic program is superior to others. This standard addresses only the images and videos and does not address the analysis or opinions being expressed by an analyst. However, the only way to fully understand the analysis being presented or discussed is to have the ability to duplicate the images or video being presented"

Samples, war stories: (not to be presented necessarily in this order)

- Wrong Side: who is on the wrong side (of the road!), Will your tools be used against you?
- Bus Launch; speed calculations for launch, assume nothing!
- Jail Time; "Expert" determines Driver Identity, who should get jail?
- Median Collision; snow/ice conditions, perception/reaction
- Preservation of Evidence; What to preserve if you use computer programs
- Occupant Simulations – Validation and Limitations
- Rear Ender – assumptions, inputs, occupant simulation tied to simulation reconstruction

General Themes of these presentations:

- Preserve inputs at the time of making reports.
- Accept nothing as a given, check and re-check calculations and assumptions.
- Check sources and resources; check reports related to topics of importance. Stay informed!
- Request all input files: Not all inputs are listed in hard copy outputs! Some hidden options and inputs are only available by loading the input file and carefully examining the inputs.
- Test sensitivities! Whether calculations are made with a calculator or computer program find out what inputs are most sensitive.
- When evaluating an opposing experts reconstruction, determine if the 'proof' is unique or the opposite conclusion can be drawn from the simulation. Make the minimum changes possible (unless of course some inputs are blatantly in error).

CONTACT INFORMATION

E-mail: **McHenry@McHenryConsultants.com** **McHenry@McHenrySoftware.com**
Postal Service Mail:

McHenry Consultants, Inc.
103 Brady Court, Suite B
Cary, NC 27511 USA

WWW: **www.mchenryconsultants.com** **www.mchenrysoftware.com**

REFERENCES

-
- 1 SAE Standard J224 MAR80
 - 2 SAE Standard J2433
 - 3 McHenry, B.G., McHenry, R.R., "CRASH-97 – Refinement of the Trajectory Solution Procedure", SAE Paper 97-0949
 - 4 Emori, R.I., "Analytical Approach to Automobile Collisions", SAE Paper 68-0016
 - 5 Campbell, K.L., "Energy Basis for Collision Severity", SAE Paper 74-0565
 - 6 McHenry, R.R., "The CRASH Program – A simplified Collision Reconstruction Program", Proceedings of the Motor Vehicle Collision Investigation Symposium, Calspan, 1975
 - 7 Test McHenry, R.R., McHenry, B.G., "Effects of Restitution in the Application of Crush Coefficients", SAE Paper 97-0960